

1  
FN-01  
FIN GLASS RAILING / PERF PANEL RAILING  
PLAN

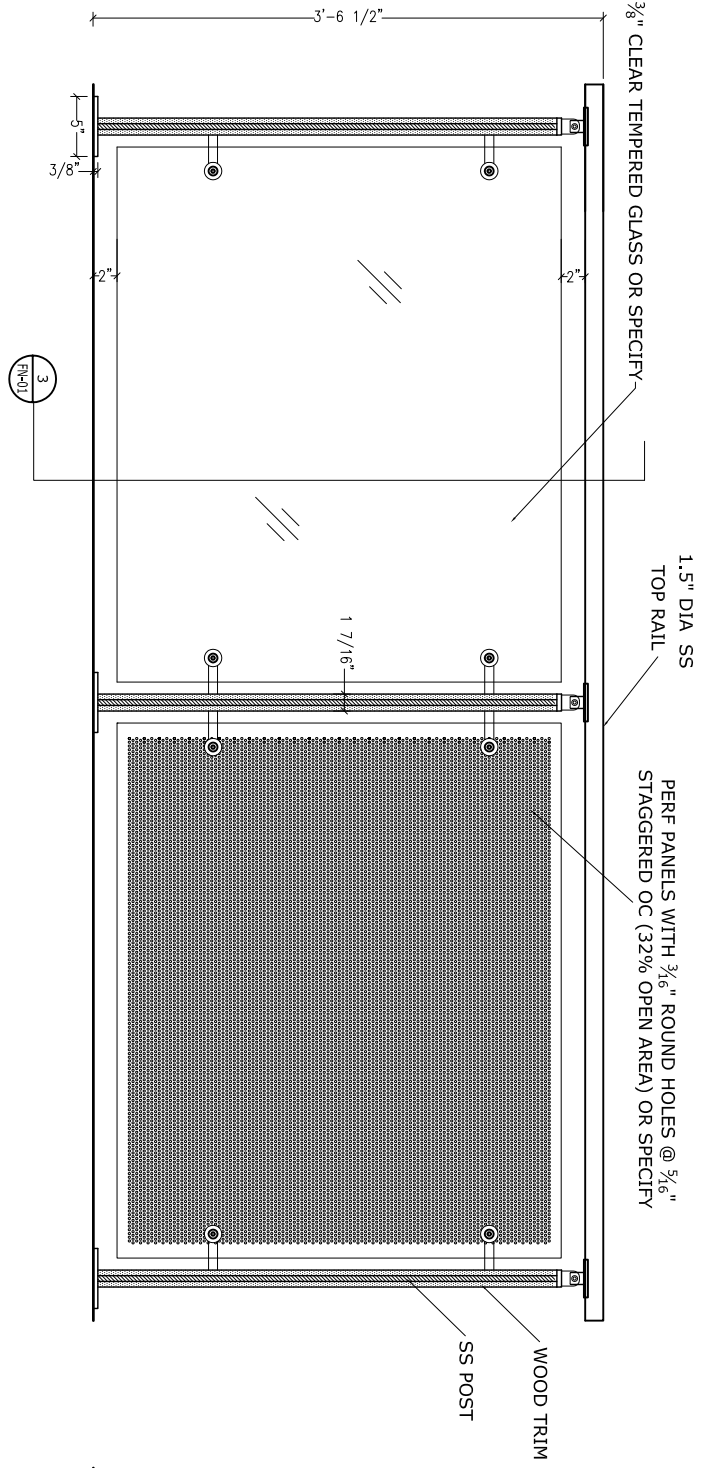

2  
FN-01  
FIN GLASS RAILING / PERF PANEL RAILING  
ELEVATION

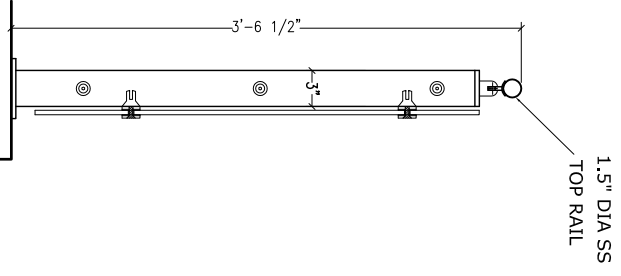

3  
FN-01  
SECTION

NO.	REVISION	DATE



VIVA ARCHITECTURAL  
401 EAST 54th ST. SUITE 1121  
NEW YORK, NY 10022  
TEL: 212 692 1111  
WWW.VIVAARCHITECTURAL.COM

PROJECT: VIVA FIN GLASS RAILING SYSTEM  
SCALE: 3/4" = 1'-0"  
DATE: 08/20/2018  
DRAWN BY: [Name]  
CHECKED BY: [Name]  
DATE: [Date]  
PROJECT NO.: [Number]

SCALE	SCALE

FIN-01

NOTE:  
REFER FN-03 FOR MOUNTING OPTIONS  
REFER FN-04 FOR CORNER OPTIONS

NO.	REVISION	DATE

1 FIN GLASS RAILING-STAIR APPLICATION PLAN

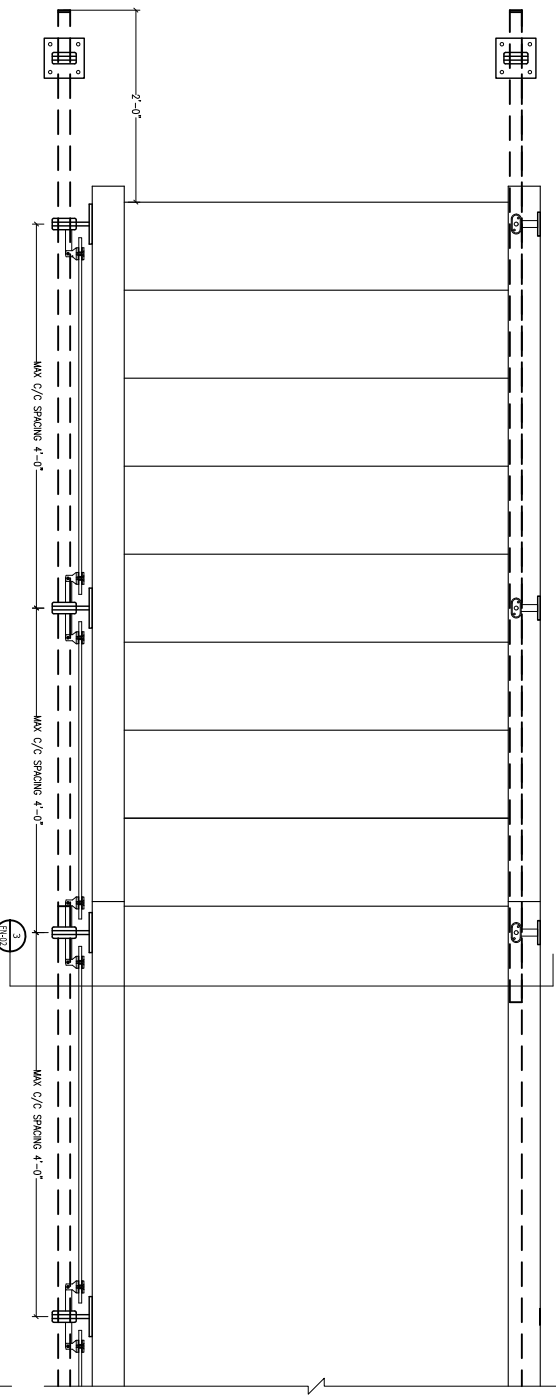

3 FIN GLASS RAILING SECTION

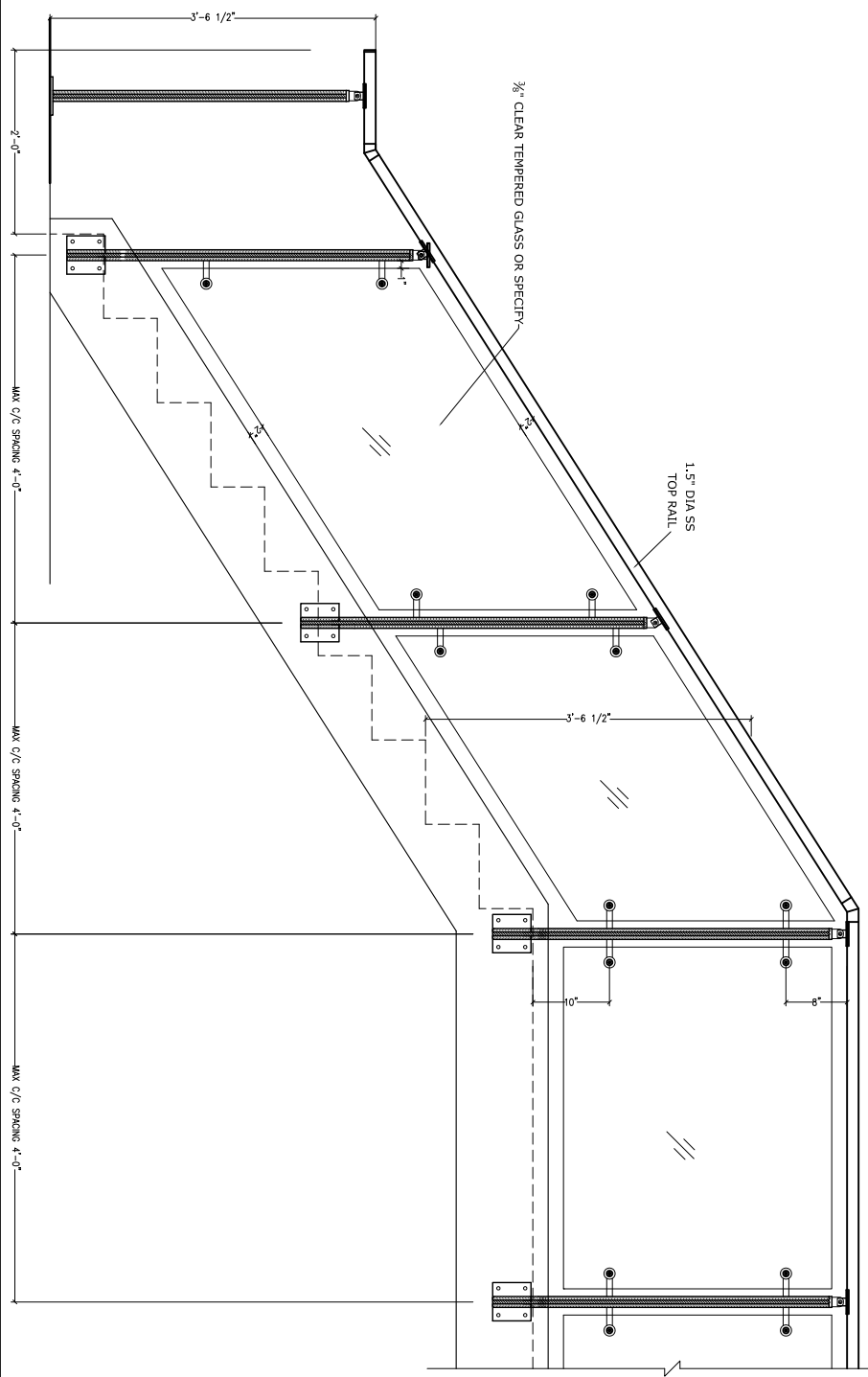
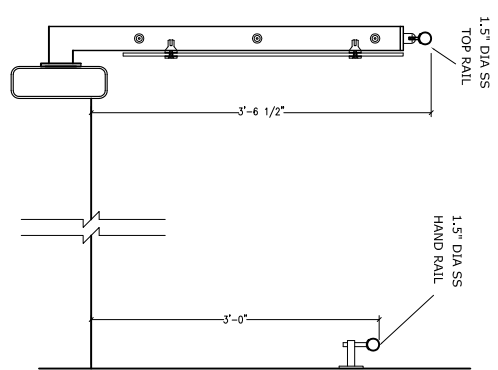

2 FIN GLASS RAILING-STAIR APPLICATION ELEVATION

SCALE	SCALE
FINISH	

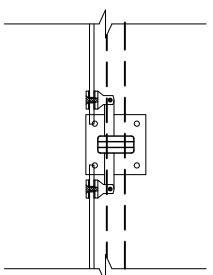

1  
FN-03  
GLASS RAILING TOP MOUNTED  
PLAN

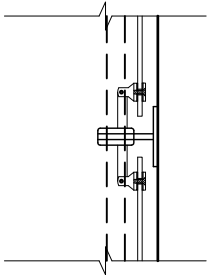

4  
FN-03  
GLASS RAILING FASCIA MOUNTED  
PLAN

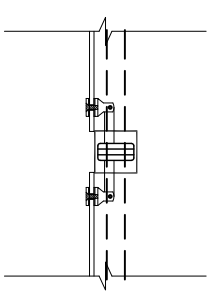

7  
FN-03  
GLASS RAILING CORE MOUNTED  
PLAN

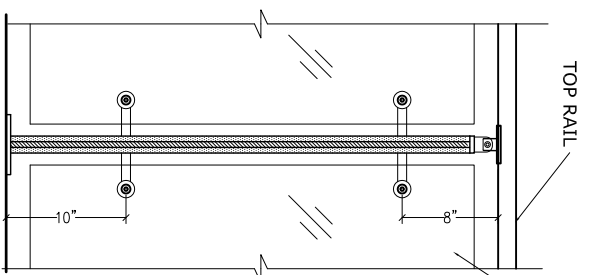

2  
FN-03  
GLASS RAILING TOP MOUNTED  
ELEVATION

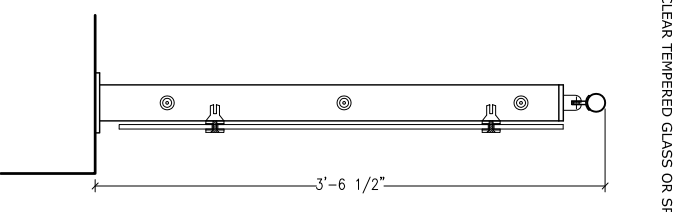

3  
FN-03  
SIDE ELEVATION

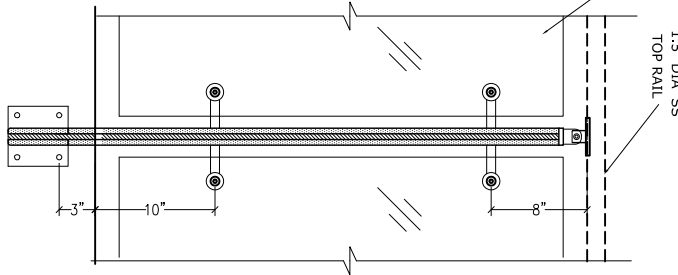

5  
FN-03  
GLASS RAILING FASCIA MOUNTED  
ELEVATION

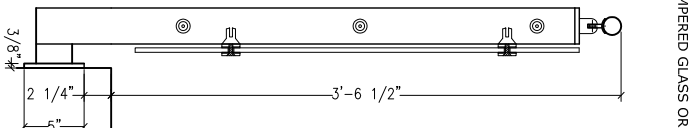

6  
FN-03  
SIDE ELEVATION

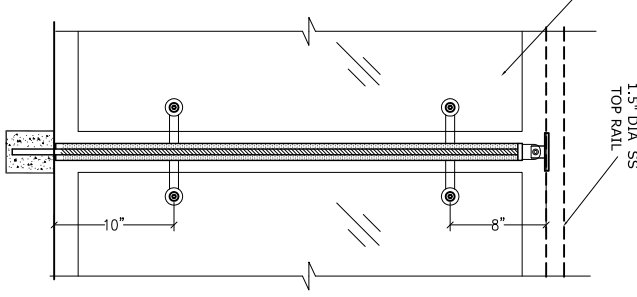

8  
FN-03  
GLASS RAILING CORE MOUNTED  
ELEVATION

TOP RAIL

3/8" CLEAR TEMPERED GLASS OR SPECIFY

1.5" DIA. SS  
TOP RAIL

3/8" CLEAR TEMPERED GLASS OR SPECIFY

1.5" DIA. SS  
TOP RAIL

10"

3'-6 1/2"

10"

3'-6 1/2"

10"

3/8"

2 1/4"

5"

NO.	REVISIONS	DATE



project: \_\_\_\_\_  
 scale: 3/4" = 1'-0"  
 submitted on: \_\_\_\_\_  
 client: \_\_\_\_\_

content: \_\_\_\_\_  
 VIA RV GLASS RAILING SYSTEM

drawn by: \_\_\_\_\_  
 checked by: \_\_\_\_\_  
 date: \_\_\_\_\_  
 drawing no: \_\_\_\_\_

SCALE	3/4" = 1'-0"
SCALE	

FN-03

REFER FN-04 FOR MORE OPTIONS

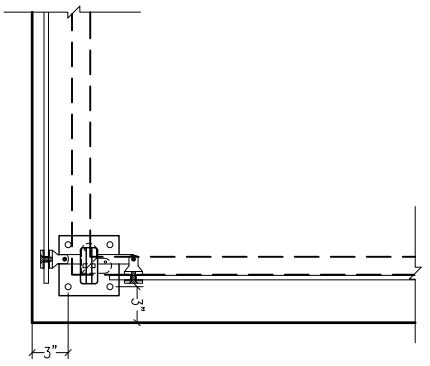

1  
FN-04  
FIN SINGLE POST CORNER  
PLAN

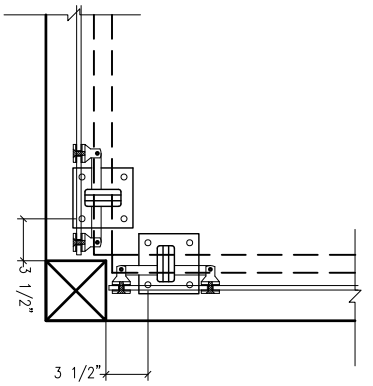

3  
FN-04  
FIN DOUBLE POST CORNER  
PLAN

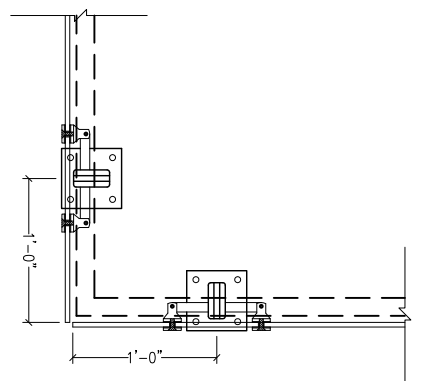

5  
FN-04  
FIN FLOATING GLASS CORNER  
PLAN

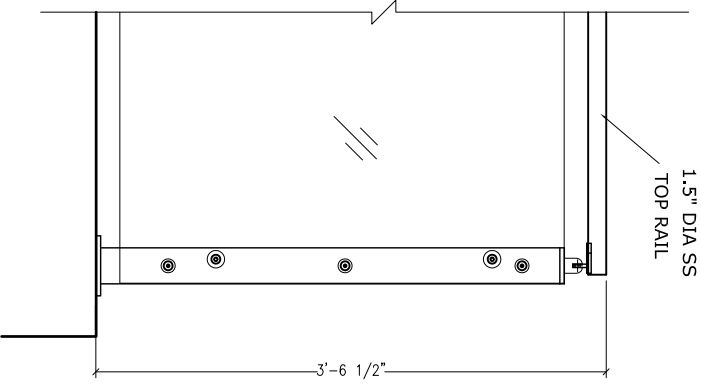

2  
FN-04  
FIN SINGLE POST CORNER  
ELEVATION

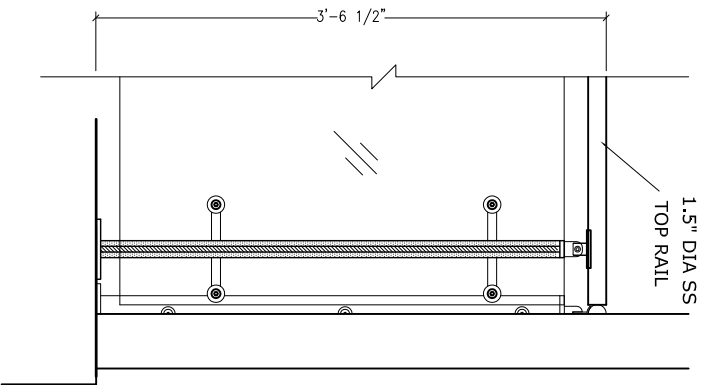

4  
FN-04  
FIN DOUBLE POST CORNER  
ELEVATION

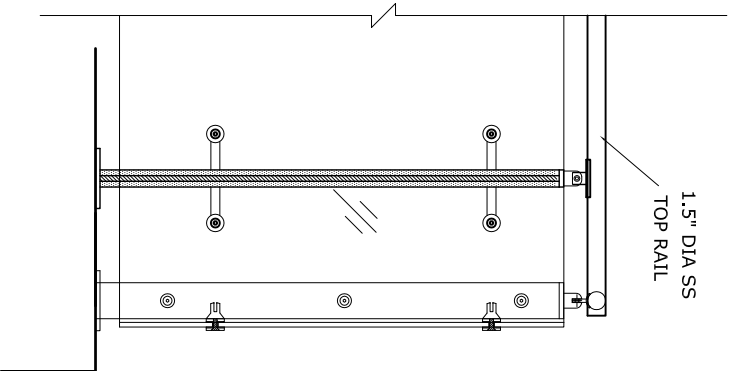

6  
FN-04  
FIN FLOATING GLASS CORNER  
ELEVATION

NO.	REVISIONS	DATE



VVA ARCHITECTURAL  
401 EAST 95th St., 1512 BUSINESS CENTER  
CINCINNATI, OH 45240  
TEL: 513-763-1111  
WWW.VVAARCHITECTURAL.COM

project: \_\_\_\_\_  
scale: 3/4" = 1'-0"  
submitted on: \_\_\_\_\_  
client: \_\_\_\_\_  
content: \_\_\_\_\_  
VIVA FIN GLASS RAILING SYSTEM

DATE	SCALE

APPROVED FOR FABRICATION  
DRAWN BY: \_\_\_\_\_  
CHECKED BY: \_\_\_\_\_  
DATE: \_\_\_\_\_  
ISSUED BY: \_\_\_\_\_  
FN-04